

J E T

10-20 PLUS DRUM SANDER

**628900M
230/50/1**

**PARTS LIST
ERSATZTEILLISTE
LISTE DE PIECES**

WMH Tool Group AG
Bahnstrasse 24, CH – 8603 Schwerzenbach
www.wmhtoolgroup.ch; info@wmhtoolgroup.ch
Tel +41 (0) 1 806 47 48
Fax +41 (0) 1 806 47 58



P-628900M 01/04

Breakdown for the 22-44 Plus Sander

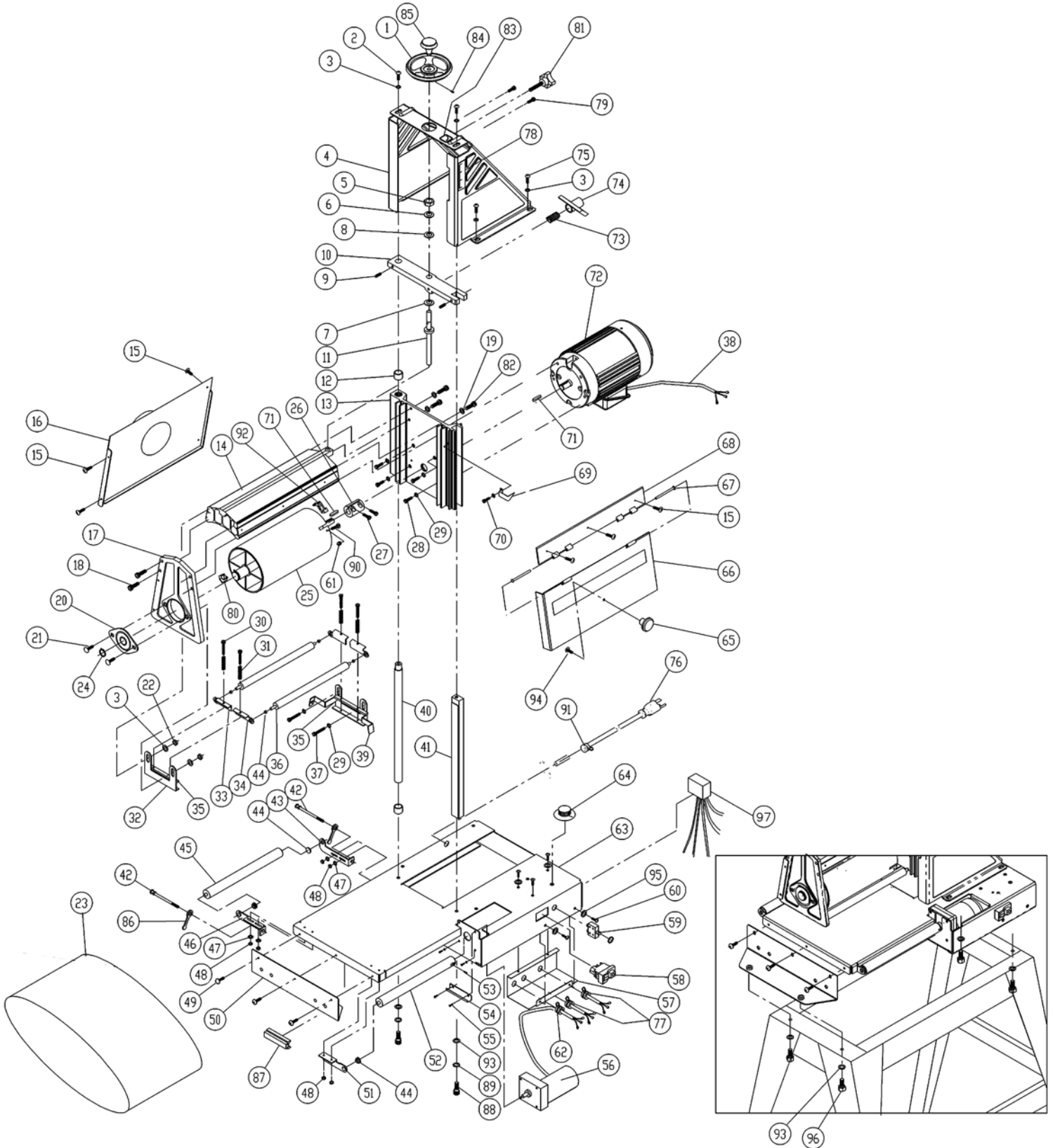

Parts List for the 10-20 Plus Sander

Index No.	Part No.	Description	Size	Qty.
1	1020-101	Handwheel, Height Adjustment		1
2	1020-102	Hex Socket Round Head Screw	5/16-18UNCx3/4	2
3	TS-0680031	Flat Washer	5/16	8
4	1020-104	Main Support		1
5	1020-105	Lock Nut	1/2-20UNF	1
6	TS-0680061	Flat Washer	1/2	1
7	1020-107	Nylon Washer		1
8	1020-108	Washer, Oilite		1
9	TS-0267051	Set Screw	1/4-20UNCx1/2	2
10	1020-110	Dog Bone		1
11	1020-111	Height Adjusting Screw		1
12	1020-112	Bushing, Oilite		2
13	1020-113	Slide Plate, Motor Mount		1
14	1020-114	Arm		1
15	1020-115	Screw	#8-32UNCx1/2	7
16	1020-116	Dust Cover		1
17	1020-117	Plate, Outboard		1
18	1020-118	Hex Socket Round Head Screw	1/4-20UNCx3/4	4
19	TS-0720071	Lock Washer	1/4	4
20	50-3089	Bearing Assembly, Drum		1
21	TS-0152011	Bolt, Carriage Head	5/16-18UNCx1	2
22	TS-0561021	Hex Nut	5/16-18UNC	2
23	60-0310-P	Conveyor Belt		1
24	20-0778	Retaining Ring	STW25	1
25	1020-125	Drum		1
26	1020-126	Main Coupler		1
27	1020-127	Socket Head Cap Screw	#8-32UNCx3/8	2
28	TS-0208041	Socket Head Cap Screw	5/16-18UNCx3/4	4
29	TS-0720081	Lock Washer	5/16	6
30	10-4008-16	Screw, Fillister Head-Phillip	#8-32UNCx1	4
31	20-3211	Spring, Tension Rollers		4
32	40-0304	Bracket, Tension Rollers		1
33	40-0308-01	Bracket, Right Tension Roller Suspension		2
34	40-0308-02	Bracket, Left Tension Roller Suspension		2
35	80-1060	Pad, Bracket-Tension Roller		2
36	1020-136	Roller, Tension		2
37	TS-0208021	Socket Head Cap Screw	5/16-18UNCx1/2	2
38	1020-138E	Motor Cord		1
39	1020-139	Bracket, Inboard Tension Roller		1
40	1020-140	Rod, Side Plate		1
41	1020-141	Rod, Square-Slide Plate		1
42	1020-142	Conveyor adjusting screw		2
43	1020-143	Bracket, Right Take-Up		1
44	50-3105	Bushing, Oilite		7
45	1020-145	Driven Roller		1
46	1020-146	Bracket, Left Take-Up		1
47	TS-0680021	Wave Washer	1/4	4
48	TS-0561011	Hex Nut	1/4-20UNC	6
49	1020-149	Screw	1/4-20UNCx3/8	3
50	1020-150	Foot Plate		1
51	1020-151	Drive Roller Support		1
52	1020-152	Drive Roller		1

53	10-4010-04	Set Screw	#10-32UNFx1/4	1
54	1020-154	Guide Plate		1
55	10-4010-08	Socket Head Cap Screw	#10-32UNFx1/2	4
56	71-1400E	Conveyer Gear Motor		1
57	1020-157	Cover, Base-Control Housing		1
58	72-2004E	Switch, On/Off-Drum		1
59	1020-159E	Overload		1
60	1020-160	Screw	#10-32UNFx1/2	5
61	12-9001	Lock Nut	#6-32UNC	2
62	72-6101	Strain Relief, DC-Motor Cord	6N-4	1
63	1020-163	Base Assembly		1
64	72-6106-01E	Controller, Conveyer-Variable Speed		1
65	80-3137	Knob		1
66	1020-166	Dust Hood, Door		1
67	20-0775	Ping, Hinge		2
68	1020-168	Dust Hood, Hinge		1
69	1020-169	Needle, Depth Gauge		1
70	1020-170	Screw	#10-24UNCx3/8	1
71	20-0762-02	Key	3/16SQx3/4"	2
72	1020-172E	Main Drum Motor		1
73	1020-173	Spring		1
74	1020-174	Adjustment Bracket		1
75	1020-175	Hex Socket Round Head Screw	5/16-24UNFx1/2	4
76	1020-176E	Power Cord		1
77	1020-177	Strain Relief, Power Cord and Motor Cord	6N3-4	2
78	94-1670E	Depth Gauge		1
79	1020-179	Hex Socket Round Head Screw	5/16-18UNCx1/2	2
80	21-1173	Fastener, Abrasive-Outboard		1
81	1020-181	Knob, Adjusting		1
82	0207041	Hex Socket Cap Screw	1/4-20UNCx3/4	4
83	94-1668E	Label, Height-Direction		1
84	1020-184	Set Screw	1/4-20UNCx1/4	2
85	80-3131	Handle Knob		1
86	40-0260	Wrench		2
87	98-0080A	Tracker Kit (2 pieces/ box)		1
88	1020-188	Shoulder Screw		2
89	1020-189	Wave Washer	3/8	2
90	10-4009-06	Screw, Flat Head-Phillips	#6-32UNCx3/8	2
91	72-6014E	Strain Relief		1
92	21-1172	Fastener, Abrasive-Inboard		1
93	TS-0680042	Flat Washer	3/8	6
94	1020-194	Screw	1/4-20UNCx5/8	1
95	TS-0680011	Flat Washer	3/16	4
96	1020-196	Hex Head Screw	3/8-16UNCx5/8	4
97	2244PLUS-112	EMC, in Control Housing		1

10-20 PIUS

628900M

230/50/1

	colour of strands	Litzenfarben	couleur des cordons
BK	black	schwarz	noir
WH	white	weiß	blanc
BU	blue	blau	bleu
YE	yellow	gelb	jaune
RD	red	rot	rouge
BN	brown	braun	brun
GY	grey	grau	gris
GNYE	green-yellow	grün-gelb	vert-jaune
OG	orange	orange	orange
VT	violet	violett	violet

	meaning of symbol	Bedeutung der Zeichen	interprétation
M	motor	Motor	moteur
S	switch	Schalter	interrupteur
C	condenser	Kondensator	condensateur
E	electronic unit	Elektronik Einheit	unité électronique
F	fuse	Sicherung	fusible
RS	reversing switch	Drehrichtungsschalter	commu. droite/gauche
CS	centrifugal switch	Fliehkraftschalter	déclencheur centrifuge
OL	overload cut-off	Überlastschuttschalter	déclencheur surcharge
LS	limit switch	Positionsendschalter	micro

